

# Clarke®

## WOODWORKER



### 40" WOODLATHE MODEL NO: CWL1000B

PART NO: 6500687

## OPERATION & MAINTENANCE INSTRUCTIONS

UK  
PA | CE



ORIGINAL INSTRUCTIONS

DL0123 - ISS 2

---

## INTRODUCTION

---

Thank you for purchasing this CLARKE Woodlathe.

Before attempting to operate the lathe, it is essential that you read this manual thoroughly and carefully follow all instructions given. In doing so you will ensure the safety of yourself and that of others around you, and you can also look forward to the product giving you long and satisfactory service.

---

## GUARANTEE

---

This CLARKE product is guaranteed against faulty manufacture for a period of 12 months from the date of purchase. Please keep your receipt as proof of purchase.

This guarantee is invalid if the product is found to have been abused or tampered with in any way, or not used for the purpose for which it was intended.

Faulty goods should be returned to their place of purchase, no product can be returned to us without prior permission.

This guarantee does not effect your statutory rights.

---

## SPECIFICATIONS

---

Weight	23.3 kg
Dimensions (L x W x H)	1420 x 200 x 345 mm
Speed	720 / 1240 / 1750 / 2150 rpm
Distance between centres	1000 mm
Turning Capacity	350 mm
Headstock Thread	3/4" x 16TPI (UNF)
IP (Ingress protection) rating	IP 20
Motor voltage/frequency	230V / 50Hz
Rated input wattage	370 W
Sound Pressure Level (Lp)	No load 70.8 dB(A) / loaded 76.6 dB(A)
Sound Power Level Measured (Lw)	No load 81.1 dB(A) / loaded 87.2 dB(A)

---

# SAFETY WARNINGS

---



CAUTION: FAILURE TO FOLLOW THESE PRECAUTIONS COULD RESULT IN PERSONAL INJURY, AND/OR DAMAGE TO PROPERTY.

---

## WORK ENVIRONMENT

1. **Keep the work area clean and well lit.** Cluttered and dark areas invite accidents.
2. **Do not operate power tools in explosive atmospheres, such as in the presence of flammable liquids, gases or dust.** Power tools create sparks which may ignite the dust or fumes.
3. **Keep children and bystanders away while operating a power tool. Anyone entering the work area must wear personal protective equipment.** Distractions can cause you to lose control and fragments of work may fly away and cause injury.
4. **Store power tools properly when not in use.** Abrasive products should be stored in a dry, secure place out of the reach of children.
5. Please read these instructions carefully and retain for future reference.

## ELECTRICAL SAFETY

1. **Power tool plugs must match the outlet. Never modify the plug in any way. Do not use adaptor plugs with earthed (grounded) power tools.** Unmodified plugs and matching outlets will reduce the risk of electric shock.
2. **Do not expose power tools to rain or wet conditions.** Water entering a power tool will increase the risk of electric shock.
3. **Do not abuse the power cable. Never use the cable for carrying, pulling or unplugging the power tool. Keep the cable away from heat, oil, sharp edges or moving parts.** Damaged or entangled cables increase the risk of electric shock.

## PERSONAL SAFETY

1. **Stay alert, watch what you are doing and use common sense when operating a power tool.** Do not use a power tool while you are tired or under the influence of drugs, alcohol or medication. A moment of inattention while operating power tools may result in personal injury.

2. **Use personal protective equipment.** Always wear eye protection. Safety equipment such as dust mask, non-skid safety shoes, hearing protection and a workshop apron capable of stopping small abrasive or workpiece fragments.
3. **Avoid accidental starting.** Ensure the switch is in the off position before plugging in. Plugging in power tools that have the switch on, invites accidents.
4. **Remove any adjusting key or wrench before turning the power tool on.** A wrench or a key left attached to a rotating part of the power tool may result in personal injury.
5. **Do not overreach.** Keep proper footing and balance at all times. This enables better control of the power tool in unexpected situations. Dress properly. Do not wear loose clothing or jewellery.
6. **Keep your hair, clothing and gloves away from moving parts.** Loose clothes, jewellery or long hair can be caught in moving parts. Keep the work area clean and tidy.
7. **Regularly clean the air vents.** The motor fan will draw dust inside the housing and accumulation of material could cause electrical hazards.
8. **Avoid operator fatigue.** Stop the lathe at regular intervals for a short break to rest hands and arms.
9. **Maintain your tools.** Keep all handles dry and clean. Keep chisels sharp.

## **ELECTRICAL SAFETY**

1. Position the power cable so that it cannot be inadvertently pulled or pinched and where it does not cause a trip hazard.
2. This lathe is designed for indoor environments and must not be used for other purposes.
3. If the lathe requires repair, always contact your Clarke dealer. Always insist on original spare parts. Repairs carried out by unauthorized persons may be dangerous and invalidate the guarantee.
4. This lathe must only be used by adults. Children should not be allowed to play with the lathe.
5. Do not use extension power cables.
6. Before cleaning or maintenance operations, always unplug the lathe from the power supply.

## **POWER TOOL USE AND CARE**

1. **Do not force the machine.** Use the correct tool for your task. It will do a better and safer job at the rate for which it was designed.

2. **Do not use the power tool if the switch does not turn it on and off.** Any power tool that cannot be controlled with the switch is dangerous and must be repaired.
3. **Disconnect the power tool from the power supply before making any adjustments, changing accessories, or storing the tool.** These measures will reduce the risk of the power tool starting accidentally.
4. **Store power tools out of the reach of children and do not allow persons unfamiliar with these instructions to operate the power tool.** Power tools are potentially dangerous in the hands of untrained users.
5. **Maintain tools in top condition.** Keep tools/ machines clean for the best and safest performance. Check for misalignment or binding of moving parts, broken parts, or any condition that may affect the power tool's operation. If damaged, have the power tool repaired before use. Many accidents are caused by poorly maintained power tools.
6. **Use recommended accessories.** The use of improper accessories could be hazardous.
7. **Machine cleanliness.** Do not allow the ventilation slots in the machine to become blocked with dust.
8. **Check the power tool for damage before using the machine.** Any damaged part should be inspected to ensure that it will operate properly and perform its intended function. Check for alignment of moving parts, breakage of parts, mountings, and any other condition that may affect the machine's operation. Any damage should be properly repaired or the part replaced. If in doubt, DO NOT use the machine. Consult your local dealer.

## SERVICING

1. **When necessary, have your power tools serviced or repaired by a qualified person using identical replacement parts.** This will ensure that the safety of the power tool is maintained.

## ADDITIONAL PRECAUTIONS FOR WOODLATHES



**WARNING: DUST GENERATED FROM CERTAIN MATERIALS CAN BE HAZARDOUS TO YOUR HEALTH. ALWAYS OPERATE THE LATHE IN A WELL VENTILATED AREA. USE A DUST COLLECTION SYSTEM WHENEVER POSSIBLE.**

1. Familiarise yourself with woodlathes and turning techniques before using the lathe. If in doubt you should consult an expert.
2. ALWAYS store chisels safely when you have finished work.
3. CAUTION: This lathe is designed for use with woodturning chisels only.
4. NEVER attempt to turn a workpiece unless a suitable support is used.

5. ALWAYS stop the lathe before removing workpieces, work supports or swarf from the table.
6. ALWAYS be sure that the workpiece is securely locked in position
7. ALWAYS keep hands and fingers away from the moving workpiece.

---

## SAFETY SYMBOLS

---

The following safety symbols may be found on the machine.



Wear a dust mask



Wear eye protection



Read instruction manual before use

---

## ENVIRONMENTAL PROTECTION

---

Recycle unwanted materials instead of disposing of them as waste. All unwanted accessories and packaging should be sorted and taken to a recycling centre for disposal in a manner which is compatible with the environment.

### ENVIRONMENTAL RECYCLING POLICY



Through purchase of this product, the customer is taking on the obligation to deal with the WEEE in accordance with the WEEE regulations in relation to the treatment, recycling & recovery and environmentally sound disposal of the WEEE.

In effect, this means that this product must not be disposed of with general household waste but according to the laws governing Waste Electrical and Electronic Equipment (WEEE) at a recognised disposal facility.

# ELECTRICAL CONNECTIONS



**WARNING: READ THESE ELECTRICAL SAFETY INSTRUCTIONS THOROUGHLY BEFORE CONNECTING THE PRODUCT TO THE MAINS SUPPLY.**

Before switching the product on, make sure that the voltage of your electricity supply is the same as that indicated on the rating plate. This product is designed to operate on 230VAC 50Hz. Connecting it to any other power source may cause damage.

This product may be fitted with a non-rewireable plug. If it is necessary to change the fuse in the plug, the fuse cover must be refitted. If the fuse cover becomes lost or damaged, the plug must not be used until a suitable replacement is obtained.

If the plug has to be changed because it is not suitable for your socket, or due to damage, it should be cut off and a replacement fitted, following the wiring instructions shown below. The old plug must be disposed of safely, as insertion into a mains socket could cause an electrical hazard.



**WARNING: THE WIRES IN THE POWER CABLE OF THIS PRODUCT ARE COLOURED IN ACCORDANCE WITH THE FOLLOWING CODE:  
BLUE = NEUTRAL    BROWN = LIVE    YELLOW AND GREEN = EARTH**

If the colours of the wires in the power cable of this product do not correspond with the markings on the terminals of your plug, proceed as follows.

- The wire which is coloured **Blue** must be connected to the terminal which is marked **N** or coloured **Black**.
- The wire which is coloured **Brown** must be connected to the terminal which is marked **L** or coloured **Red**.
- The wire which is coloured **Yellow and Green** must be connected to the terminal which is marked **E** or  or coloured **Green**.

**Plug must be BS1363/A approved.**

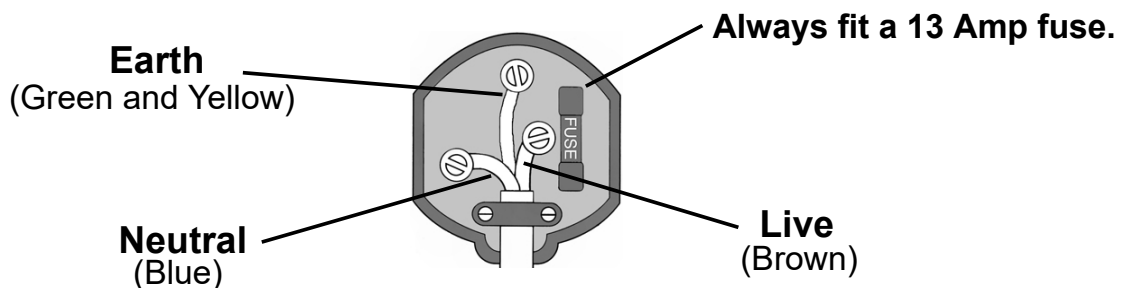

**Ensure that the outer sheath of the cable is firmly held by the clamp**

We strongly recommend that this machine is connected to the mains supply via a Residual Current Device (RCD)

If in any doubt, consult a qualified electrician.

# CONTENTS

Check that all components are present and undamaged. Should any loss or damage be apparent, please contact your CLARKE dealer immediately.

The following components are supplied loose with the lathe assembly.

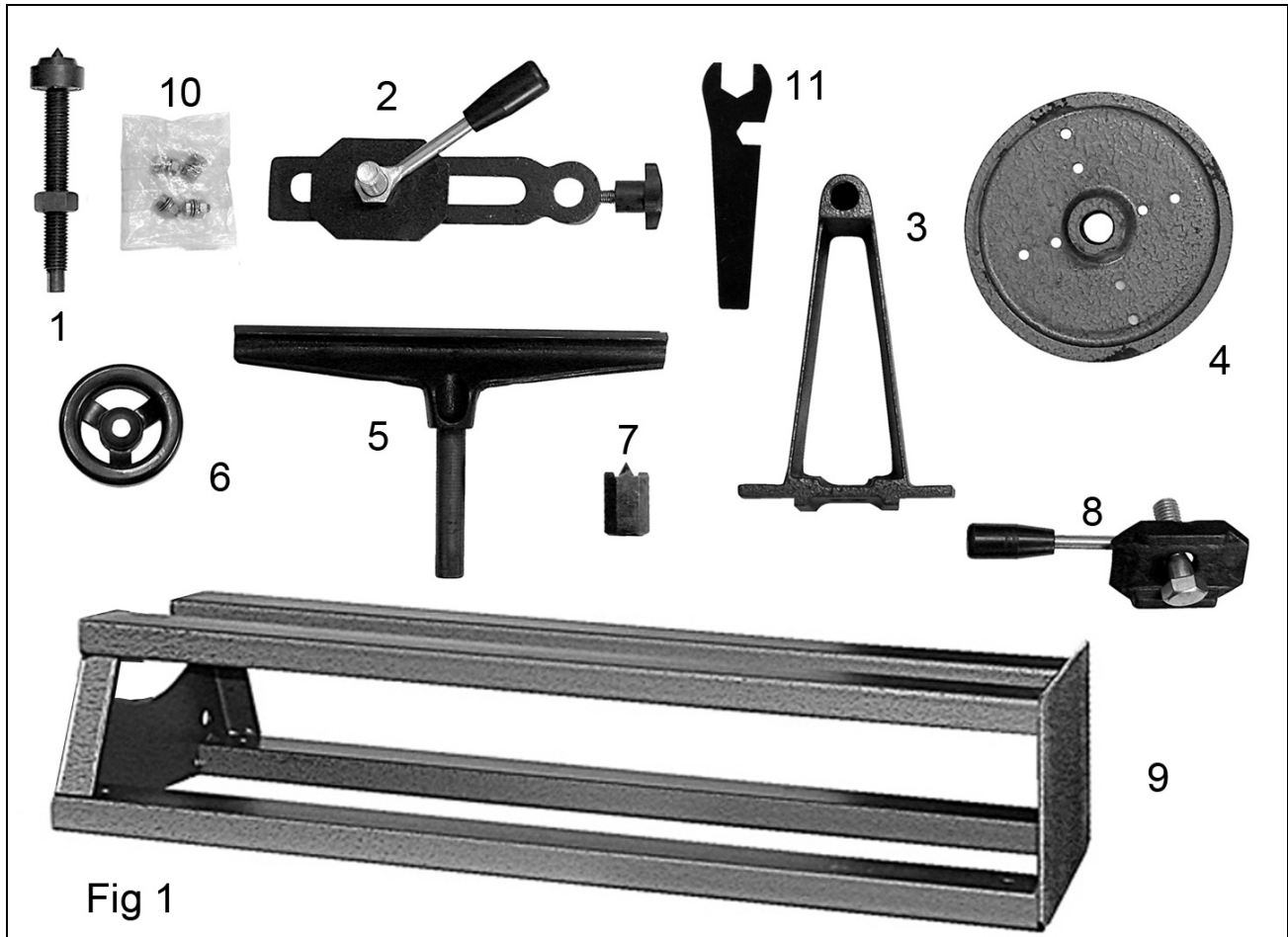

Fig 1

Item	Description
1	Tailstock spindle
2	Toolrest clamp assembly
3	Tailstock
4	Faceplate
5	Tool rest
6	Tailstock advance handle

Item	Description
7	Drive centre
8	Tailstock clamp assembly
9	Bed extension
10	Fixing kit (bolts/nuts/washers)
11	Spanner
-/-	Set of 3 chisels



# MAIN COMPONENTS

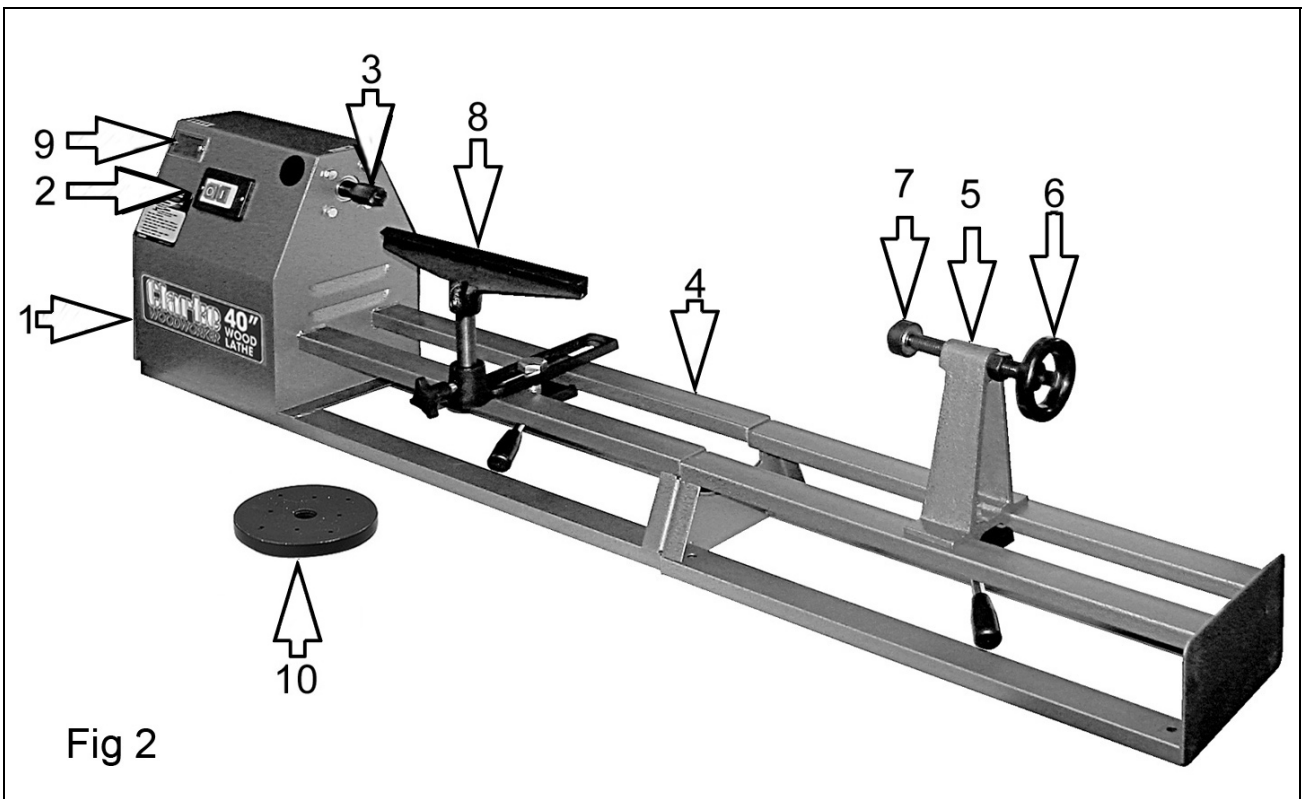
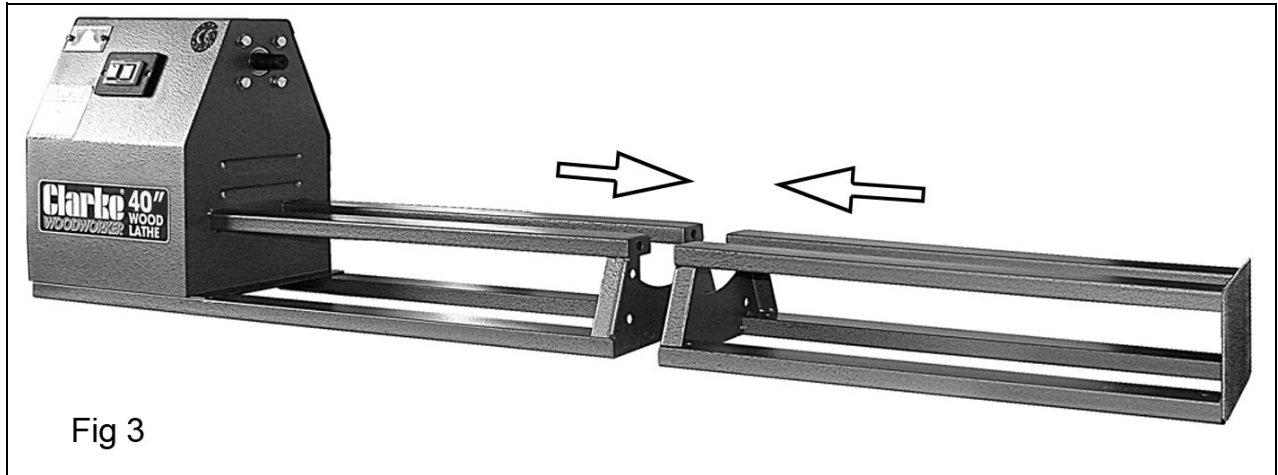

Fig 2

Item	Description	Item	Description
1	Headstock	6	Tailstock advance handle
2	On/Off switches	7	Tailstock revolving centre
3	Drive centre	8	Toolrest
4	Bed	9	Pulley viewing window
5	Tailstock	10	Faceplate

## ASSEMBLY

1. Bolt the two halves of the bed together, using the four nuts, bolts and washers supplied. Make sure that the two halves are aligned so that the assembly lies flat on the work surface.



2. Place the tailstock on the bed and assemble the tail stock clamp assembly (8 in Fig 1) to the tail stock with the bolt through the hole in the tail stock, passing through the clamping plate and into the lever.

3. Note the orientation of the components-;

- The tailstock should be orientated as shown.
- The clamping plate has raised edges which sit between the bed rails.
- The lever should be angled downwards.

4. Screw in the bolt and nip up tight using the lever.

**NOTE:** The position of the lever, when fully tightened, should be towards the operator as shown. This is achieved by slackening off the lever and turning the bolt head until the appropriate position is achieved when the lever is tightened again.

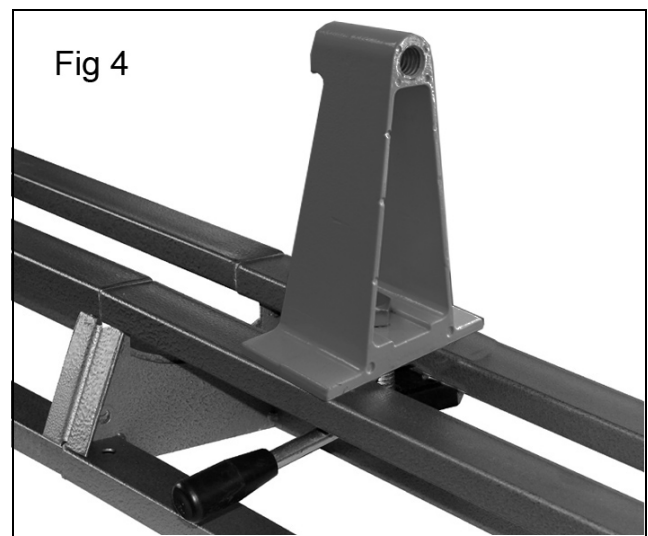

5. Screw the tail shaft into the tailstock and screw on the locking nut.
6. Fit the handle to the flats on the end of the shaft and secure the handle by tightening the grub screw.

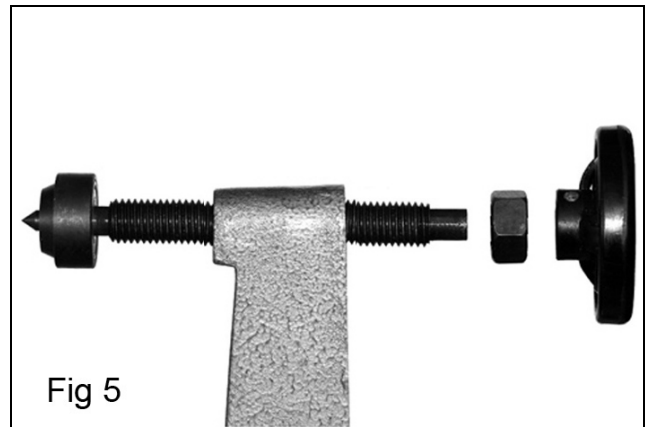

7. Assemble the tool support bracket to the machine as shown in Fig 6. The clamping bracket and lever should be fitted and oriented in the same manner as the tailstock.
8. The tool rest (5 in Fig 1) is simply dropped into the hole in the bracket and secured using the knob provided.

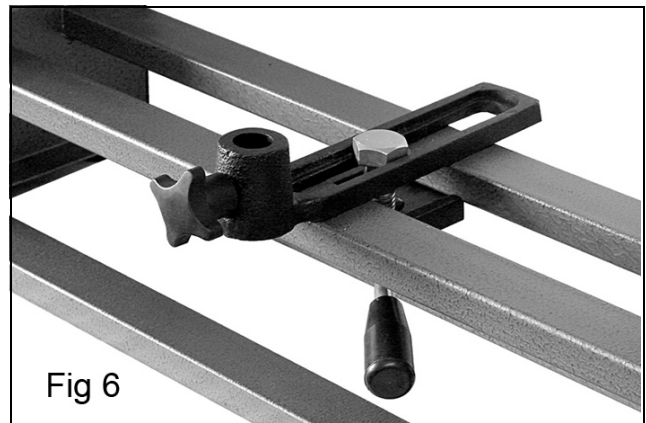

9. Screw the lathe to a workbench using the eight holes provided in the bed. (see fig 7)
10. Alternatively, bolt the lathe to a piece of board of at least 18 mm in thickness and having a plan dimension of at least 1500 x 500 mm.

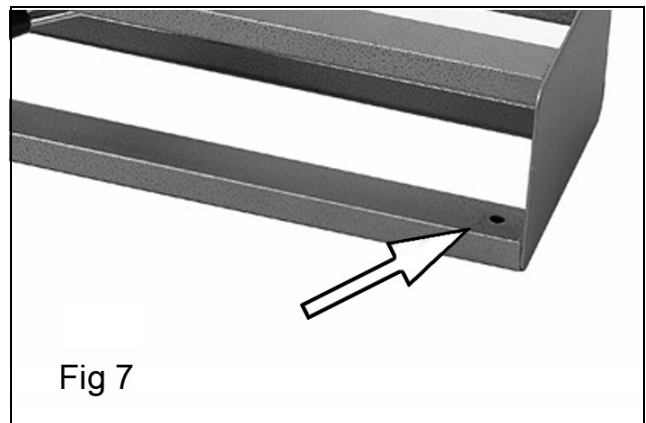

11. Use countersunk bolts from beneath the board so that the complete assembly lies flat. The board, with the lathe attached, may then be firmly clamped to a workbench when required for use.

12. Before use, either the centre spur or the face plate must be attached to the headstock.

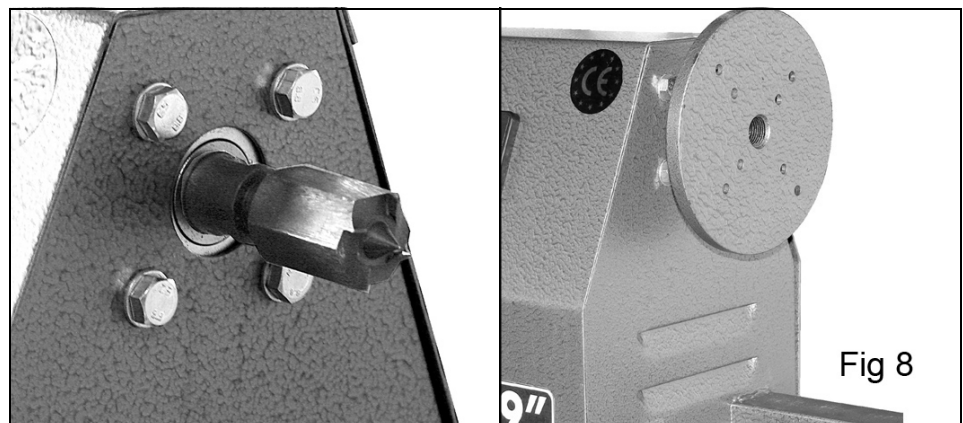

13. These are simply

screwed to the headstock, the drive spindle being held using the spanner provided, to grip the flats on the spindle.

14. Your lathe is now fully assembled and ready for use.

## SPINDLE SPEEDS

The position of the drive belt on the pulleys is visible through the viewing window and marked on the top of the lathe as shown below.

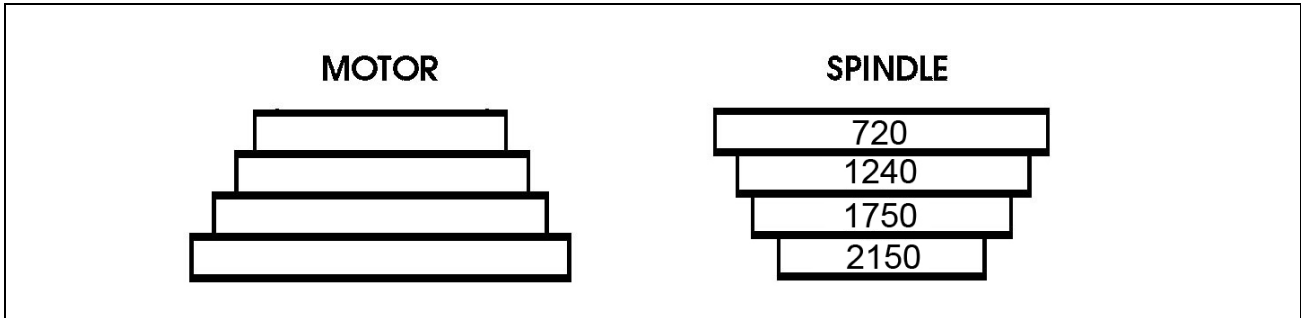

## RECOMMENDED RUNNING SPEEDS

### SPINDLE TURNING

SQUARE	LENGTH
1" (25 mm)	12" (305 mm)
2" (50 mm)	16" (406 mm)
3" (75 mm)	20" (508 mm)
4" (100 mm)	20" (508 mm)

ROUGHING	FINISHING
1750	2550
1240	2550
720	2550
720	2550

## FACEPLATE TURNING

SQUARE	LENGTH
1" (25mm)	12" (305mm)
2" (50mm)	16" (406mm)
3" (75mm)	20" (508mm)
4" (100mm)	20" (508mm)

ROUGHING	FINISHING
1750	2550
1240	2550
720	2550
720	2550

Fig 9 shows the belt positioned on the second step from the outside face of the pulley. This produces a spindle speed of 1750 rpm. (Refer to the chart above).

If you wish to run at a higher speed, say 2150 rpm, you must shift the belt outwards, one step.

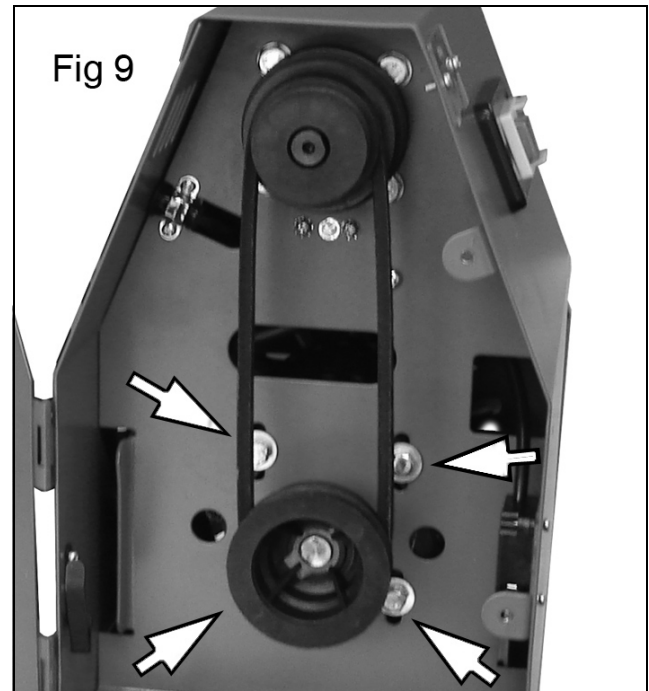

## CHANGING SPEEDS

1. Undo the two screws securing the pulley access cover.
2. Slacken the four motor securing bolts shown in Fig 9.
3. Pull up the lower motor pulley to relieve belt tension.
4. Move the belt to the appropriate pulleys.
5. Push down on the lower pulley to tension the belt. It should be firm - 1/2" total movement at the centre of the span.
6. Retighten the motor securing bolts.
7. Re-secure the end cover.
  - The motor will not run if the cover is not secured.

---

## OPERATION

---

1. Make sure that the tool rest and tailstock are securely locked in position before starting work.
2. Always rotate the workpiece by hand before turning on the motor and check it does not strike the tool/tool rest.
3. Always use the lowest speed when starting a new workpiece and roughly turn the work to a round shape at low speed.
4. Always position the tool-rest just above the centre-line of the workpiece.
5. Avoid turning timber which has splits or substantial knots or voids and take special care if these are discovered.
6. Take care that the chisels do not bite suddenly into the workpiece.
7. Press the green push-button to start the lathe.

---

## MAINTENANCE

---

Always inspect before use. Any damage should be repaired and faults rectified. The lathe requires very little maintenance other than the following guidelines.

***IMPORTANT: Disconnect from mains power before cleaning.***

1. Vacuum clean any dust or shavings that accumulate.
2. Check periodically that the power cable is in good condition and not cracked.
3. Check the tightness of the mounting bolts.
4. Check the drive belt for wear and replace if it is frayed or otherwise damaged.
5. Very occasionally lubricate the tailstock screw thread and tool-post locking handles with engine oil such as SAE20 or SAE30 grade if it becomes stiff to use.
  - The bearings in the headstock and tailstock spindles are greased and permanently sealed at the factory requiring no further lubrication.

## REPLACING THE BELT

1. Open the end cover and loosen the four bolts shown in Fig 10.
  - This will enable the drive motor to move and the drive belt to become slack.
2. Remove the drive belt from the drive pulleys.
3. Replacement is a reversal of the removal procedure. Tension the belt by pushing the motor downwards before tightening the bolts.
4. Re-secure the end cover.
  - The motor will not run if the cover is not secured.

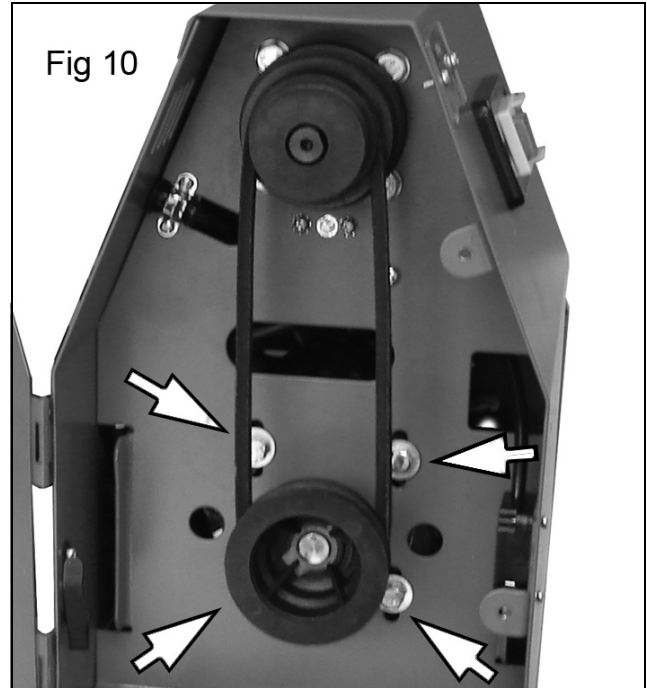

Please refer to TROUBLESHOOTING on page 16. If you are unable to rectify any faults, please contact your local dealer or Clarke International Service Department on 0208 988 7400 for assistance.

---

## OPTIONAL ACCESSORIES

---

The following are available from your local Clarke supplier.

Cup Turning Chuck	6500676
Screw Chuck	6500677
4-Jaw Independent Lathe Chuck	6500678
6" Faceplate	6500679
8 Piece Chisel Set	6500649

## TROUBLESHOOTING

Problem	Check	Solution
Motor stops and will not run.	<ol style="list-style-type: none"> <li>1. Overload switch has tripped due to excessive load on the chuck.</li> <li>2. Defective/broken switch. Damaged power cable.</li> </ol>	<ol style="list-style-type: none"> <li>1. Switch off and wait for the components to cool down and the overload to re-set. Then turn the lathe back on Send to your Clarke dealer for repair.</li> <li>2. Send to your Clarke dealer for replacement.</li> </ol>
Motor will not start and fuses or circuit breaker trip out.	<ol style="list-style-type: none"> <li>1. Short circuit in motor or power cable.</li> </ol>	<ol style="list-style-type: none"> <li>1. Send to your Clarke dealer for repair.</li> </ol>
Motor fails to reach full power.	<ol style="list-style-type: none"> <li>1. Overloaded circuit.</li> <li>2. Unsuitable extension cable</li> </ol>	<ol style="list-style-type: none"> <li>1. Turn off other machines &amp; retry.</li> <li>2. Consult electrician and replace with correct type.</li> </ol>
Noisy operation	<ol style="list-style-type: none"> <li>1. Incorrect belt tension.</li> <li>2. Worn spindle bearings</li> <li>3. Loose drive pulley.</li> </ol>	<ol style="list-style-type: none"> <li>1. Adjust belt tension. See Replacing the Belt on p15.</li> <li>2. Send to your Clarke dealer for replacement</li> <li>3. Tighten the retaining set screw on the pulley.</li> </ol>



# DECLARATION OF CONFORMITY

**UKCA**

**Clarke**  
INTERNATIONAL

Hennell Street, Epping, Essex, CM16 4LG

**DECLARATION OF CONFORMITY**

This is an important document and should be retained.

We hereby declare that this product(s) complies with the following legislation:

*Electromagnetic Compatibility Regulations 2016*  
*Supply of Machinery (Safety) Regulations 2008*  
*The Restriction of the Use of Certain Hazardous Substances in Electrical and Electronic Equipment Regulations 2012*

The following standards have been applied to the product(s):

EN IEC 55014-1:2021, EN IEC 55014-2:2021, EN 61000-3-2:2019+A1:2021,  
EN 61000-3-3:2013+A1:2019+A2:2021, EN 62841-1:2015+AC:2015,  
IEC 62841-1:2014+C1:2014+C2:2015.

The technical documentation required to demonstrate that the product(s) meet(s) the requirement(s) of the aforementioned legislation has been compiled and is available for inspection by the relevant enforcement authorities.

The UKCA mark was first applied in: 2023

Product Description: 40" Wood Turning Lathe  
Model Number(s): CWL1000B  
Serial/Batch Number: Refer to product/packaging label  
Date of Issue: 26/01/2023

Signed:   
J.A. Clarke  
Director

CWL1000B UKCA Doc 012623

Page 1 of 1

**CE**

**Clarke**  
INTERNATIONAL

Fitzwilliam Hall, Fitzwilliam Place, Dublin 2

**DECLARATION OF CONFORMITY**

This is an important document and should be retained.

We hereby declare that this product(s) complies with the following legislation:

2014/30/EU *Electromagnetic Compatibility Directive*  
2006/42/EC *Machinery Directive*  
2011/65/EU *Restriction of the Use of Certain Hazardous Substances in Electrical & Electronic Equipment (RoHS) Directive*

The following standards have been applied to the product(s):

EN IEC 55014-1:2021, EN IEC 55014-2:2021, EN 61000-3-2:2019+A1:2021,  
EN 61000-3-3:2013+A1:2019+A2:2021, EN 62841-1:2015+AC:2015,  
IEC 62841-1:2014+C1:2014+C2:2015.

The technical documentation required to demonstrate that the product(s) meet(s) the requirement(s) of the aforementioned legislation has been compiled and is available for inspection by the relevant enforcement authorities.

The CE mark was first applied in: 2017

Product Description: 40" Wood Turning Lathe  
Model Number(s): CWL1000B  
Serial/Batch Number: Refer to product/packaging label  
Date of Issue: 26/01/2023

Signed:   
J.A. Clarke  
Director

CWL1000B CE Doc 012623

Page 1 of 1

# PARTS DIAGRAM

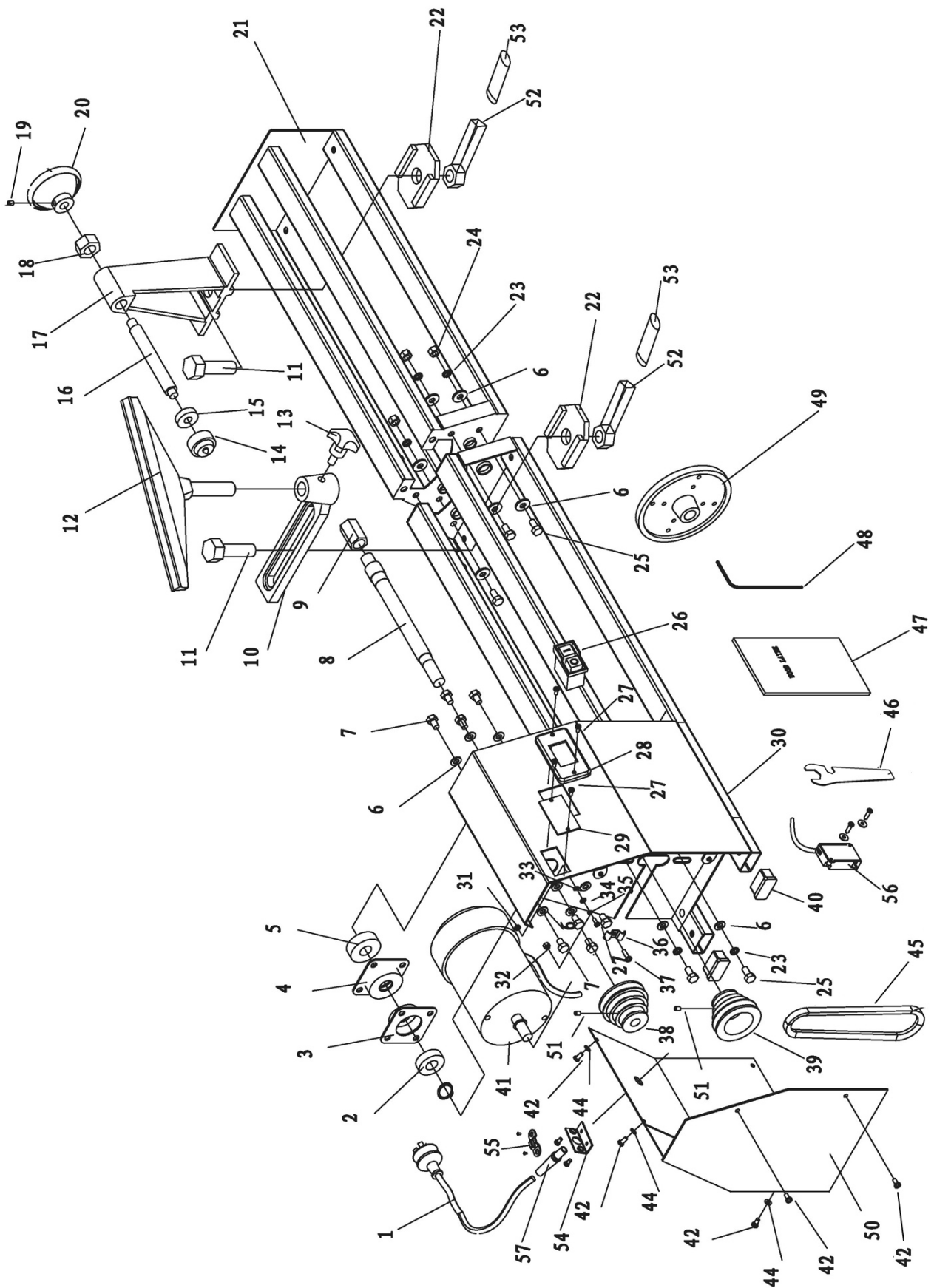

# PARTS LIST

PART NO	DESCRIPTION	PART NO	DESCRIPTION
1	Power Cable	30	Headstock Frame
2	Ball Bearing	31	Nut
3	Bearing Block	32	Nut
4	Bearing Block	33	Lock Washer
5	Ball Bearing	34	Washers
6	Washer	35	Spring Washer
7	Bolt	36	Wire clip
8	Headstock Spindle	37	Screw
9	Centre Spur	38	Upper Belt Pulley
10	Tool Post Support	39	Lower Belt Pulley
11	Locking Bolt	40	End Cap
12	Tool Rest	41	Motor
13	Locking Knob	42	Screw
14	Tailstock Centre	43	Cable Clamp
15	Ball Bearing	44	Washer
16	Tail Shaft	45	Drive Belt
17	Tailstock	46	Spanner
18	Nut	47	User manual
19	Grub Screw	48	Allen Key
20	Hand Wheel	49	Face Plate
21	Bed Extension	50	End Cover Plate
22	Clamping Plate	51	Grub Screw
23	Spring Washer	52	Locking Handle
24	Nut	53	Handgrip
25	Bolt	54	Cable Bracket
26	Switch	55	Cable Retainer
27	Screw	56	Micro Switch
28	Switch Bracket	57	Cable Gland
29	Viewing Window		

# A SELECTION FROM THE VAST RANGE OF

# Clarke®

## QUALITY PRODUCTS



**AIR COMPRESSORS**  
From DIY to industrial, Plus air tools, spray guns and accessories.

**GENERATORS**  
Prime duty or emergency standby for business, home and leisure.

**POWER WASHERS**  
Hot and cold, electric and engine driven - we have what you need

**WELDERS**  
Mig, Arc, Tig and Spot. From DIY to auto/industrial.

**METALWORKING**  
Drills, grinders and saws for DIY and professional use.

**WOODWORKING**  
Saws, sanders, lathes, mortisers and dust extraction.

**HYDRAULICS**  
Cranes, body repair kits, transmission jacks for all types of workshop use.

**WATER PUMPS**  
Submersible, electric and engine driven for DIY, agriculture and industry.

**POWERTOOLS**  
Angle grinders, cordless drill sets, saws and sanders.

**STARTERS/CHARGERS**  
All sizes for car and commercial use.



## PARTS & SERVICE: 0208 988 7400

**Parts Enquiries**  
[Parts@clarkeinternational.com](mailto:Parts@clarkeinternational.com)

**Servicing & Technical Enquiries**  
[Service@clarkeinternational.com](mailto:Service@clarkeinternational.com)

SALES: UK 01992 565333 or Export 00 44 (0)1992 565335

**Clarke** INTERNATIONAL Hemnall Street, Epping, Essex CM16 4LG  
[www.clarkeinternational.com](http://www.clarkeinternational.com)